

EXTERNAL INVOLUTE SPLINE DATA

FLAT ROOT SIDE FIT TOLERANCE CLASS - 6 SPECIAL
SIMILAR TO ANSI B92.2M-1980 (R1989)

NUMBER OF TEETH	39
MODULE	1.5000
PRESSURE ANGLE	30.0°
PITCH DIAMETER (REF)	58.500
BASE DIAMETER (REF)	50.662
MAJOR DIAMETER	60.00-59.75
MINOR DIAMETER	56.25-55.96
FORM DIAMETER (MAX.)	56.79
CIRCULAR TOOTH THICKNESS MAX. EFFECTIVE	2.232
CIRCULAR TOOTH THICKNESS MIN. ACTUAL	2.126
FILLET RADIUS MINIMUM	N/A
PIN DIAMETER	3.000
MEASUREMENT OVER PINS (REF)	63.021-62.919

INTERNAL INVOLUTE SPLINE DATA

FLAT ROOT SIDE FIT TOLERANCE CLASS - 6 MODIFIED
SIMILAR TO ANSI B92.1-1996

NUMBER OF TEETH	27
MODULE	1.0583
PRESSURE ANGLE	30.0°
PITCH DIAMETER (REF)	28.575
BASE DIAMETER (REF)	24.747
MAJOR DIAMETER	30.73-30.48
MINOR DIAMETER	28.07-27.94
FORM DIAMETER (MIN.)	29.85
CIRCULAR TOOTH SPACE MIN. EFFECTIVE	1.821
CIRCULAR TOOTH SPACE MAX. ACTUAL	1.923
FILLET RADIUS MINIMUM	N/A
PIN DIAMETER	2.032
MEASUREMENT BETWEEN PINS (REF)	25.729-25.559

EXTERNAL HELICAL GEAR DATA

NUMBER OF TEETH	50
NORMAL MODULE	1.4571
NORMAL PRESSURE ANGLE	20.0°
HELIX ANGLE	23.383°
HAND OF HELIX	LEFT
LEAD	578.7070
PITCH DIAMETER (REF)	79.374
BASE DIAMETER (REF)	73.784
MAJOR DIAMETER	81.23-81.03
MINOR DIAMETER	73.19-72.81
CHAMFER DIAMETER (MINIMUM)	80.47
CHAMFER INCLUDED ANGLE	80.0°-140.0°
T.I.F. DIAMETER (MAXIMUM)	76.11
TRANSVERSE CIRCULAR TOOTH THICKNESS	1.675-1.624
BALL DIAMETER	3.175
MEASUREMENT OVER BALLS	83.448-83.327
BACKLASH WITH MATING PART ON 52.895 CENTER DISTANCE	0.206-0.104
FOR LEAD AND INVOLUTE SPECIFICATIONS SEE SHEET #2	

HEAT TREAT:
K232ME (10-00-447-232-D)
OPT: K232MEJ (10-00-447-232-D)

SHAFT SURFACE FINISH: THE SURFACE FINISH AT THE SHAFT/SEAL INTERFACE SHALL BE 0.25-0.50 MICROMETERS (10-20 MICROINCHES) RA AND SHALL HAVE NO LEAD (AS DEFINED IN BorgWarner SPEC. #44-00-430-032.)

UNLESS OTHERWISE SPECIFIED:
RADIUS: 0.8 ±0.4
CHAMFERS: 27° ±5°
CORNER BREAKS: 1.5 X 35° - 55°

PART MUST MEET BorgWarner SPEC. #44-00-447-008

PART MUST BE FREE FROM BURRS AND SHARP CORNERS

EXTERNAL SPLINES MUST BE ACCEPTED BY A "GO COMPOSITE RING GAGE" MADE TO THE MAXIMUM EFFECTIVE SPLINE TOOTH THICKNESS. SPLINES MUST MEET THE MINIMUM DIMENSION OVER PINS SPECIFIED.

INTERNAL SPLINES MUST BE ACCEPTED BY A "GO COMPOSITE PLUG GAGE" MADE TO THE MINIMUM EFFECTIVE SPLINE SPACE WIDTH. SPLINES MUST MEET THE MAXIMUM DIMENSION BETWEEN PINS SPECIFIED.

SPLINE GAGE PRACTICES AND TOLERANCES MUST CONFORM TO ANSI B92.1-1996 AND ANSI B92.2M-1980 (R1989) AS NOTED.

SHT.	LET.	ZONE	DESCRIPTION	DATE	BY	OK'D.
-	A	--	DWO-6111, RELEASED FOR PROTOTYPE	11-5-04	A M	S.T.
1	B1	B6	DWO-6111, ADDED "Ø 4.0" DIM.	11-30-04	A M	DWN
1	B2	B6	DWO-6111, ADDED "LOCATION" NOTE	11-30-04	A M	DWN
1	B3	B4	DWO-6111, ADDED "53.42" DIM.	11-30-04	A M	DWN
1	C1	A3	DWO-6111, WAS "SAE J946 10.1-10.5"	1-31-05	A M	DWN
1	C2	D7	DWO-6111, "30°" WAS "(30°)"	1-31-05	A M	DWN
1	C3	D7	DWO-6111, ADDED "30°" DIM.	1-31-05	A M	DWN
1	C4	D8	DWO-6111, ADDED "2.0" DIM.	1-31-05	A M	DWN

G.D. & T. IN ACCORDANCE WITH ASME Y14.5M-1994		TOLERANCES UNLESS OTHERWISE SPECIFIED: X.X±0.4 X.XX±0.15 ANGLES±5°		THIRD ANGLE PROJECTION -METRIC-	
RELEASE TO PROD. T.R.# DATE:		W.O. NO. DWO-6111		REF. NO. 44-93-189-004	
CHANGE RESTRICTED NO MANUAL CHANGES		SPECIAL CHARACTERISTIC UNLESS OTHERWISE SPECIFIED ALL FINISHED SURFACES TO BE 5.0/		TITLE SHAFT - INPUT	
MATERIAL U.N.S. HB6200 Rc 31-37 @ J4		HEAT TREAT SEE NOTE		DRN, GULVAS DATE 10-12-04	
DESIGN REL. ENG. JVS/VDJUC DATE 10-20-04		ENGR. APP'D, DWN DATE 11-4-04		DWG. NO.	
MFG. APP'D, XXXX DATE XX-XX-XX		SCALE FULL		DO NOT SCALE SIZE D SHEET 1 of 2	

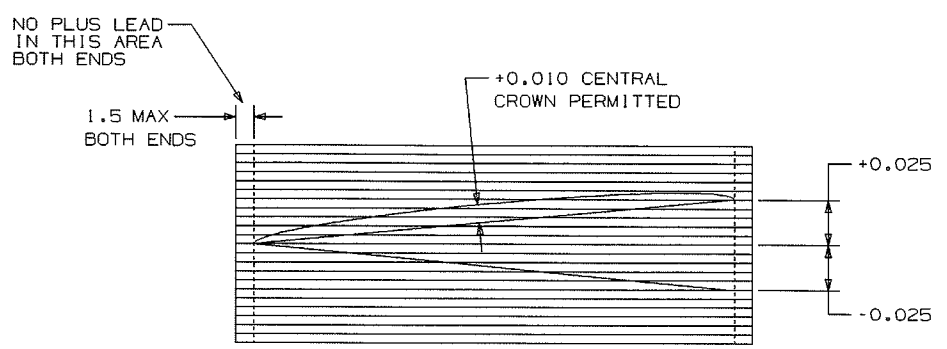

LEAD CHART

THE LEAD ON ANY FOUR TEETH SPACED APPROXIMATELY 90° APART MUST CONFORM TO THE ABOVE CHART AND THE FOLLOWING SPECIFICATIONS:

- A. NO HOLLOWES PERMITTED.
- B. LEAD IRREGULARITY NOT TO EXCEED 0.025 ON ANY TOOTH.
- C. LEAD VARIATION BETWEEN ANY TWO TEETH NOT TO EXCEED 0.050.
- D. GEAR CROWN MUST BE WITHIN THE LIMITS SHOWN.

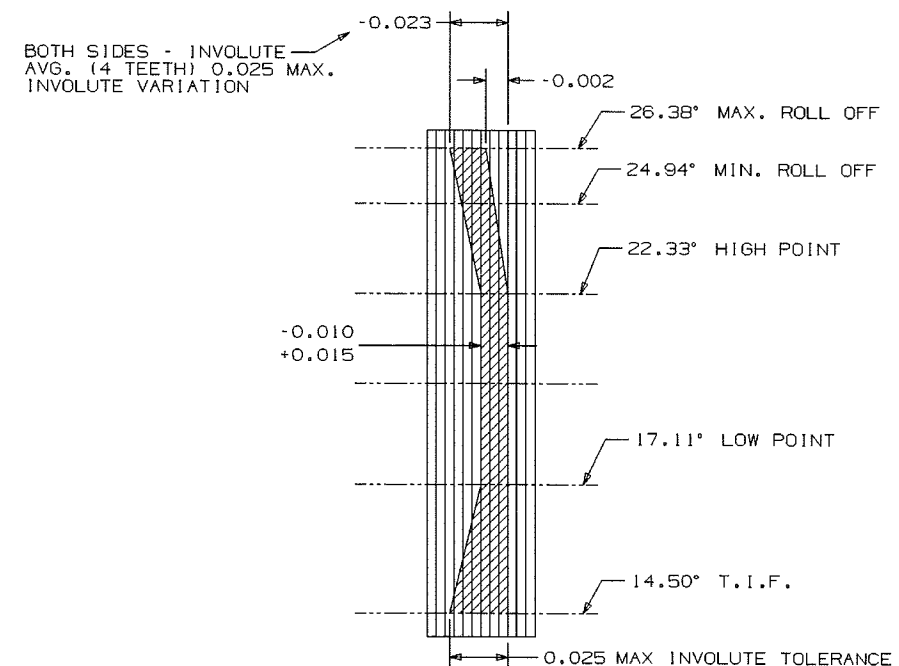

50 TOOTH GEAR MEMBER

THE INVOLUTE TRACE OF EACH OF ANY FOUR TEETH SPACED APPROXIMATELY 90° APART MUST BE WITHIN THE ABOVE CHART AND THE FOLLOWING SPECIFICATIONS:

- A. THE TRACE FROM THE HIGHEST POINT ON THE INVOLUTE TO THE POINT OF OUTSIDE DIAMETER AND THE FORM DIAMETER SHALL NOT BE A STRAIGHT LINE OR A CONVEX CURVE.
- B. NO HOLLOWES PERMITTED BETWEEN LOW POINT AND HIGH POINT.
- C. +0.010 MAX. CENTRAL CROWN PERMITTED BETWEEN LOW POINT AND HIGH POINT.
- D. NO PLUS INVOLUTE ALLOWED FOR 3° MIN. ROLL ANGLE BELOW T.I.F. DIAMETER.
- E. THE INVOLUTE FORM IS DEFINED FURTHER FOR THE DRIVE AND COAST SIDES AS FOLLOWS:
 1. THE SLOPE OF THE LINE JOINING THE INVOLUTE'S INTERSECTION WITH THE LOW POINT AND T.I.F. ROLL ANGLES SHALL BE +0.000 TO +0.025.
 2. THE SLOPE OF THE LINE JOINING THE INVOLUTE'S INTERSECTION WITH THE LOW POINT AND HIGH POINT ROLL ANGLES SHALL BE -0.010 TO +0.015.
 3. THE SLOPE OF THE LINE JOINING THE INVOLUTE'S INTERSECTION WITH THE HIGH POINT AND MAXIMUM SPECIFIED ROLL ANGLES SHALL BE -0.002 TO -0.023.

G.D. & T. IN ACCORDANCE WITH ASME Y14.5M-1994		TOLERANCES UNLESS OTHERWISE SPECIFIED: X.XX±0.4 X.XXX±0.15 ANGLES±45°		THIRD ANGLE PROJECTION 	-METRIC-
CHANGE RESTRICTED NO MANUAL CHANGES		RELEASE TO PROD. T.R.# DATE: W.O. NO. DWO-6111			
◇ SPECIAL CHARACTERISTIC		REF. NO. SEE SHEET #1		TITLE SHAFT - INPUT	
UNLESS OTHERWISE SPECIFIED ALL FINISHED SURFACES TO BE 5-V		WEIGHT ---		MATERIAL SEE SHEET #1	
ASME Y14.35M-1996		FINISH ---		HEAT TREAT SEE SHEET #1	
THIS DRAWING AND THE INFORMATION CONTAINED THEREON ARE THE PROPERTY OF BORGWARNER. SUCH INFORMATION, DESIGN, DRAWING OR ANY COPIES THEREOF, IN WHOLE OR IN PART, MAY NOT BE DISCLOSED OR DISTRIBUTED TO OTHERS AND MAY ONLY BE USED FOR THE BENEFIT OF BORGWARNER AND/OR IN CONNECTION WITH GOODS PURCHASED FROM BORGWARNER.		DATE 10-12-04		DATE 10-15-04	
DRN. GULVAS		CHK'D A.J.M.		DESIGN REL. ENG. J.S.VADDOVIC	
DATE 11-4-04		DATE 11-4-04		DATE 10-20-04	
MFG. APP'D. XXXX		SCALE FULL		DO NOT SCALE	
DATE XX-XX-XX		SIZE		SHEET 2 OF 2	